

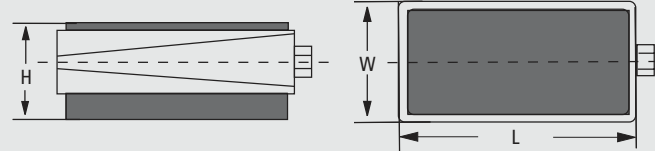

Precision Leveling Wedge



Krauss Maffei injection molding machine on precision leveling wedge



A

range of application  
**Component Set A**

Top:  
Anti-skid pad BR 7-1  
Bottom:  
Isolation pad B 4-1

General tool and graphic machines, in particular machines with horizontal components.  
High anti-slip protection!

type	load daN/pc.	length L mm	width W mm	height H in intermediate pos. mm	range of adjustment mm
PK 1-A	450	105	55	59	8
PK 2-A	900	150	75	63	10
PK 3-A	1800	200	95	67	10
PK 3/72-A	1800	200	95	94	10
PK 4-A	4000	200	200	70	12
PK 4/72-A	4000	200	200	94	12
PK 5-A	5000	200	250	94	18
PK 6-A	8200	250	330	94	18
PK 7-A	12000	300	400	94	20
PK 8-A	20000	400	500	97	20
PK 9-A	30000	500	600	172	22



B

range of application  
**Component Set B**

Top:  
Anti-skid pad BS  
Bottom:  
Isolation pad BO

Special design for CNC lathes, surfaces and cylindrical grinders, drilling and milling machines, machining centers, transfer lines.

type	load daN/pc.	length L mm	width W mm	height H in intermediate pos. mm	range of adjustment mm
PK 1-B	600	105	55	54	8
PK 2-B	1300	150	75	58	10
PK 3-B	2200	200	95	63	10
PK 3/72-B	2200	200	95	89	10
PK 4-B	4800	200	200	66	12
PK 4/72-B	4800	200	200	89	12
PK 5-B	6000	200	250	89	18
PK 6-B	10000	250	330	89	18
PK 7-B	15000	300	400	89	20
PK 8-B	24000	400	500	92	20
PK 9-B	36000	500	600	167	22



C

range of application  
**Component Set C**

Top:  
Anti-skid pad BS  
Bottom:  
Isolation pad B 32

For highly effective isolation in the active and passive range. In particular when used on upper floors. Please ask for our advice, without obligation, regarding any critical situation.

type	load daN/pc.	length L mm	width W mm	height H in intermediate pos. mm	range of adjustment mm
PK 1-C	400	105	55	64	8
PK 2-C	800	150	75	68	10
PK 3-C	1500	200	95	73	10
PK 3/72-C	1500	200	95	99	10
PK 4-C	3200	200	200	76	12
PK 4/72-C	3200	200	200	99	12
PK 5-C	4000	200	250	99	18
PK 6-C	6500	250	330	99	18
PK 7-C	10000	300	400	99	20
PK 8-C	16000	400	500	102	20
PK 9-C	25000	500	600	177	22

for vibration and structure borne noise isolation

## Precision Leveling Wedge

BILZ Precision Leveling Wedges are manufactured in three different types; free standing (PK Series), bolt-on to the machine (PKA Series), bolt-through to the foundation (PKD Series). The design permits the highest precision leveling range of 1/100 mm. Creep from their preset position is prevented by the self-locking design. Large support surfaces provide optimum foundation support and rigidity. Any of the BILZ Isolation materials can be bonded to the leveling wedge to provide the required isolation.

## Precision Leveling Wedge, Series PK (free-standing)

BILZ Precision Leveling Wedges **PK** are used where a firm mounting with the machine is not required. The high coefficient of friction of the isolation materials and anti-skid pads keep the machine in place.

### Wrench sizes A /F for BILZ PKs

type	inside	outside	type	inside	outside
PK 1	SW 6	SW 13	PKA/PKD 1	SW 10	SW 19
PK 2	SW 10	SW 19	PKA/PKD 2	SW 12	SW 22
PK 3	SW 12	SW 22	PKA/PKD 3	SW 12	SW 22
PK 4	SW 12	SW 22	PKA/PKD 4	SW 14	SW 27
PK 5	SW 14	SW 27	PKA/PKD 5	SW 14	SW 27
PK 6	SW 14	SW 27	PKA/PKD 6	SW 17	SW 32
PK 7	SW 17	SW 32	PKA/PKD 7	SW 19	SW 41
PK 8	SW 19	SW 41	PKA/PKD 8	SW 22	SW 50
PK 9	SW 22	SW 50			

**Notice: We are always pleased to fulfill special requests!**



**D**

range of application  
**Component Set D**

Top:  
Anti-skid pad BR 7-1  
Bottom:  
Isolation pad B 5

For machines with extremely high dynamic forces such as presses, stamping machines, shears etc.

type	load daN/pc.	length L mm	width W mm	height H in intermediate pos. mm	range of adjustment mm
PK 1-D	800	105	55	67	8
PK 2-D	1300	150	75	71	10
PK 3-D	2500	200	95	76	10
PK 3/72-D	2500	200	95	104	10
PK 4-D	5500	200	200	79	12
PK 4/72-D	5500	200	200	104	12
PK 5-D	7000	200	250	104	18
PK 6-D	10000	250	330	104	18
PK 7-D	16000	300	400	104	20
PK 8-D	30000	400	500	107	20
PK 9-D	45000	500	600	182	22



**E**

range of application  
**Component Set E**

Top:  
Anti-skid pad BS  
Bottom:  
Isolation pad BS

For all machines and systems requiring no vibration isolation. Ideally suited for leveling machines.

type	load daN/pc.	length L mm	width W mm	height H in intermediate pos. mm	range of adjustment mm
PK 1-E	1400	105	55	41	8
PK 2-E	3500	150	75	45	10
PK 3-E	5700	200	95	49	10
PK 3/72-E	5700	200	95	76	10
PK 4-E	12000	200	200	52	12
PK 4/72-E	12000	200	200	76	12
PK 5-E	20000	200	250	76	18
PK 6-E	25000	250	330	76	18
PK 7-E	35000	300	400	76	20
PK 8-E	60000	400	500	79	20
PK 9-E	90000	500	600	154	22

Good stability due to non-slip character of pads. Extremely compact design!



**F**

range of application  
**Component Set F**

Top:  
Anti-skid pad BS  
Bottom:  
Isolation pad B 6

For extremely high load capacity.

Very high level consistency.

type	load daN/pc.	length L mm	width W mm	height H in intermediate pos. mm	range of adjustment mm
PK 1-F	2000	105	55	54	8
PK 2-F	4000	150	75	58	10
PK 3-F	6500	200	95	63	10
PK 3/72-F	6500	200	95	89	10
PK 4-F	14000	200	200	66	12
PK 4/72-F	14000	200	200	89	12
PK 5-F	21000	200	250	89	18
PK 6-F	28000	250	330	89	18
PK 7-F	45000	300	400	89	20
PK 8-F	70000	400	500	92	20
PK 9-F	110000	500	600	167	22



Gildemeister NEF 330  
on precision leveling wedges

## ○ Precision Leveling Wedge, Series PKA

(bolt-on)

BILZ precision leveling wedges **PKA** are used where a firm mounting with the machine is required. Preferably on machines with a high axial thrust such as die casting machines, injection machines, shock testing machines, and cold extrusion presses etc.

**Notice:** We are always pleased to fulfill special requests!

**PKA 1-0 up to PKA 8-0**

**Range of application:** lathes, horizontal drilling machines, surface and cylindrical grinders, machining centers

Equipment:

Bottom: **Isolation pad B0**

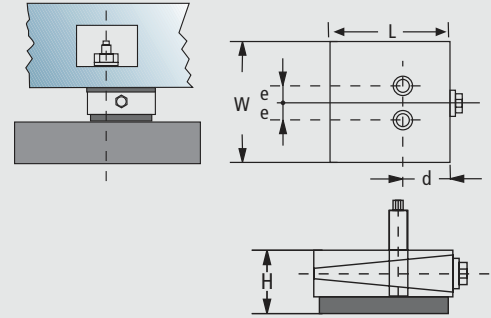

**PKA 1-4 up to PKA 8-4**

**Range of application:** Plastic extrusion machines, pressure die casting machines, planers, shock testing machines, cold extrusion presses etc.

Equipment:

Bottom: **Isolation pad B 4-1**

Very good anti-slip properties.

Screws can be supplied upon request (page 15).

type	PKA 1-0	PKA 2-0	PKA 3-0	PKA 3/72-0	PKA 4-0	PKA 5-0	PKA 6-0	PKA 7-0	PKA 8-0	PKA 1-4	PKA 2-4	PKA 3-4	PKA 3/72-4	PKA 4-4	PKA 5-4	PKA 6-4	PKA 7-4	PKA 8-4
load daN/pc.	1300	2200	4800	4800	6000	10000	15000	24000	36000	1000	1800	4000	4000	5000	10000	15000	24000	36000
length L mm	130	150	200	200	200	250	300	400	500	115	150	200	200	200	250	300	400	500
width W mm	115	150	200	200	250	330	400	500	600	115	150	200	200	250	330	400	500	600
height H in intermediate position mm	60	63	63	87	88	88	90	90	165	60	63	63	87	88	88	90	90	165
d mm	50	60	75	75	95	125	150	200	255	50	60	75	75	95	125	150	200	255
e mm	24	23	27	27	27	27	105	130	150	24	23	27	27	27	105	100	130	150
inside thread	M 16	M 18	M 20	M 20	M 20	M 24	M 24	M 24	M 30	M 16	M 18	M 20	M 20	M 20	M 24	M 24	M 24	M 30
range of adjustment mm	8	10	12	12	18	18	20	20	22	8	10	12	12	18	18	20	20	22

## ○ Screw-on base plate for PKA / PKAK precision leveling wedges



BILZ base plates provide a simple method for anchoring the machine to the ground. Base plates are attached to the precision leveling wedges with four countersunk-head screws. The base plates can be attached in three different mounting positions to fit different installation requirements.

More information available on request!

## Precision Leveling Wedge, Series PKD

(bolt-through)

BILZ precision leveling wedge PKD are used for machines which need to be fixed to a foundation, due their unfavorable stability. Also for machines which must be "squeezed" or "pulled" when being aligned – e.g. for machines with little natural rigidity!

**PKD 1-0 to PKD 8-0**

**Range of application:** drilling and milling machines, machining centers, special machines, long lathes, long planers

Bottom: **Isolation pad B0**

Screws, nuts and anchors can be supplied upon request (page 15).

**Notice:**

We are always pleased to fulfill special requests!!

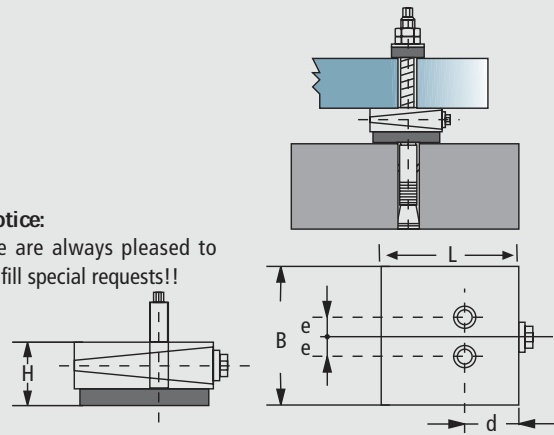

type	PKD 1-0	PKD 2-0	PKD 3-0	PKD 3/72-0	PKD 4-0	PKD 5-0	PKD 6-0	PKD 7-0	PKD 8-0	load daN/pc.	length L mm	width W mm	height H in intermediate pos. mm	d mm	e mm	bore ø	range of adjustment mm
										1300	115	115	60	50	24	22	8
										2200	150	150	63	60	23	22	10
										4800	200	200	63	80	27	26	12
										4800	200	200	87	75	27	26	12
										6000	200	250	88	95	27	26	18
										10000	250	330	88	125	105	26	18
										15000	300	400	90	150	100	30	20
										24000	400	500	90	200	130	35	20
										36000	500	600	165	255	150	35	22

## With spherical seating PKAK / PKDK

Precision Wedge, Series PKAK (bolt-on)

Series PKDK (bolt-through)

BILZ precision leveling wedge PKAK / PKDK are used to compensate angular differences between machines and foundations. Especially for machines with a long bed and high demands in alignment.

**PKDK 1-0 to PKDK 4-0**

**Range of application:** drilling and milling machines, machining centers, special machines, long lathes, long planers

Bottom: **Isolation pad B0**

**Notice:**

We are always pleased to fulfill special requests!!

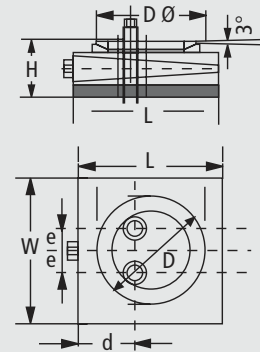

type	PKAK 1-0	PKAK 2-0	PKAK 3-0	PKAK 4-0	PKDK 1-0	PKDK 2-0	PKDK 3-0	PKDK 4-0	load daN/pc.	length L mm	width W mm	height H in intermediate pos. mm	D mm	d mm	e mm	bore / threaded ø	range of adjustment mm
									1300	115	115	70	110	50	24	M 16	8
									2200	150	150	78	150	60	23	M 18	10
									4800	200	200	79	150	80	27	M 20	12
									6000	200	250	104	150	95	27	M 20	18
									1300	115	115	70	110	50	24	22	8
									2200	150	150	78	150	60	23	22	10
									4800	200	200	79	150	75	27	26	12
									6000	200	250	104	150	95	27	26	18

## Precision wedge PKAE

In stainless steel

**Notice:**

We are always pleased to fulfill special requests!!



type	PKAE 1-0	PKAE 2-0	load daN/pc.	length L mm	width W mm	height H in intermediate pos. mm	d mm	e mm	inside thread	range of adjustment mm
			1300	115	115	60	50	24	M 16	8
			2200	150	150	63	60	23	M 18	10